

7SG163 Ohmega 300 Series

7SG163 Protection Relay

Document Release History

This document is issue 2012/01. The list of revisions up to and including this issue is:
Pre release

2010/02	Document reformat due to rebrand
2012/01	Figure 1 terminal numbering corrected

Software Revision History

--	--	--

The copyright and other intellectual property rights in this document, and in any model or article produced from it (and including any registered or unregistered design rights) are the property of Siemens Protection Devices Limited. No part of this document shall be reproduced or modified or stored in another form, in any data retrieval system, without the permission of Siemens Protection Devices Limited, nor shall any model or article be reproduced from this document unless Siemens Protection Devices Limited consent.

While the information and guidance given in this document is believed to be correct, no liability shall be accepted for any loss or damage caused by any error or omission, whether such error or omission is the result of negligence or any other cause. Any and all such liability is disclaimed.

Contents

1	Introduction	3
2	DEF Direction and Characteristic Angle	3
2.1	DEF Schemes	4
2.1.1	DEF Direct Trip	4
2.1.2	DEF POR	4
2.1.2.1	Current Reversal Guard	4
2.1.2.2	CB Echo	4
3	Relay Settings	5
3.1	DEF Auxiliary Protection Settings	5
3.2	DEF Protection Status Inputs	5
3.3	DEF Protection Outputs	5

1 Introduction.

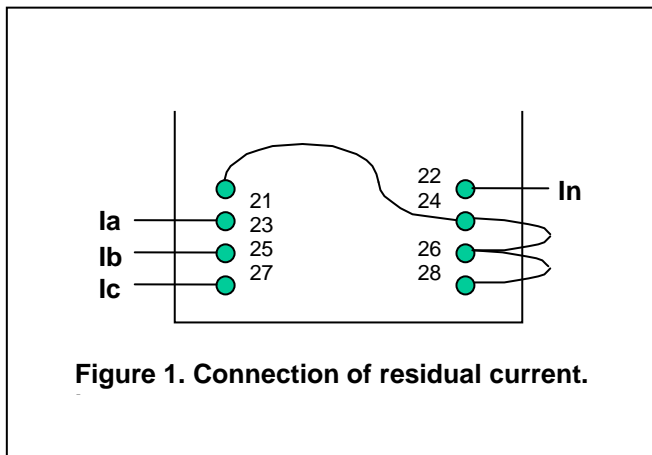

High resistance earth faults present difficulties to impedance measuring elements since the resistive coverage required can often extend beyond the apparent impedance presented by maximum load conditions. In those cases a directional earth fault element can be used to supplement the basic distance protection.

The design of the directional earth fault element is based on similar techniques as used for impedance measurement. The element is voltage polarised deriving this by summing the three phase to neutral voltages available in the relay. The zero sequence current providing the other input is derived from the fourth C.T. input which must be connected as indicated in Figure 1.

2 DEF Direction and Characteristic Angle.

The direction element can be set to operate in the forward or reverse direction. With the DEF Direction set to forward, relay operation will occur for fault current occurring within the forward operating zone. With the relay set to reverse operation will occur for fault current occurring within the reverse operating zone. This can be seen in figure 2.

The Characteristic Angle sets the maximum torque angle of the directional relay. Operation will occur for angles in the range $\pm 85^\circ$ of this setting, as shown in the diagram below:

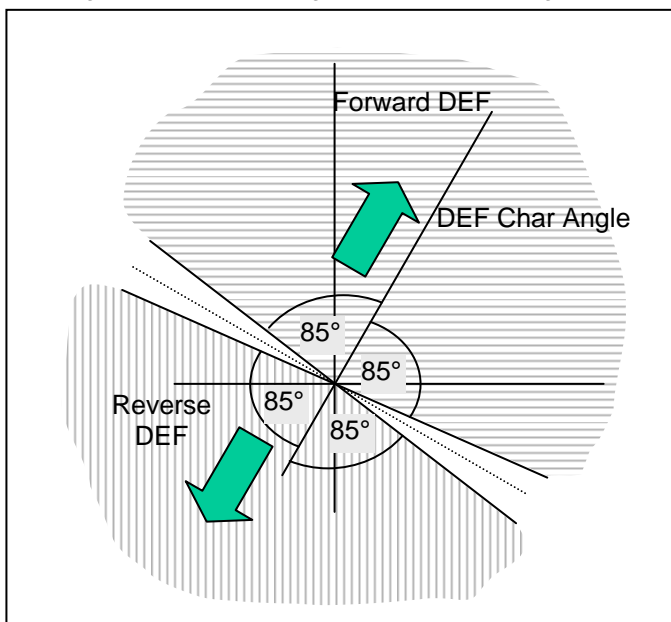

The DEF element is normally used with a signalling channel, operating as a simple high speed directional comparison scheme in conjunction with the remote end DEF. This is referred to as a DEF POR (Permissive Overreach Scheme).

If the signalling channel fails, however, a the relay will carry out a time delayed backup trip if the residual current is detected, and not cleared after a time delay.

The element can also be used with no signalling as a time graded directional IDMTL relay. This mode is referred to as DEF DIRECT TRIP.

Figure 2. DEF Operating Zones

2.1 DEF Schemes

There are two active schemes for the relay.

2.1.1 DEF Direct Trip

In the *DEF Direct Trip* mode, the relay will trip on detecting an earth fault in the set direction. The DEF element is time graded, and may be set to standard IEC or ANSI Curves or as a DTL element.

2.1.2 DEF POR

The other DEF scheme is *DEF POR* (permissive overreach). This is designed to be used in conjunction with a signalling channel, to form a directional comparison scheme. When the DEF element operates it sends a permissive signal, using the output contact assigned as *Signal Send 2*, to the remote end. In order to trip instantaneously on DEF the relay must detect an earth fault on the forward direction and have received a signal to Status Input *Signal Receive 2* from the remote end. Obviously if the relays at both ends of the line detect a fault in the forward direction, the fault must be within the line section, and tripping should be carried out instantaneously.

In case the signalling channel fails, if the DEF element operates, and no signal is received from the remote end, the relay will carry out a time delayed DEF back-up trip.

Additional logic is included within the DEF Scheme to ensure correct operation of the relay.

2.1.2.1 Current Reversal Guard

A current reversal guard is included to prevent incorrect tripping on parallel feeders. Consider a fault at Point F on the parallel line system shown below:

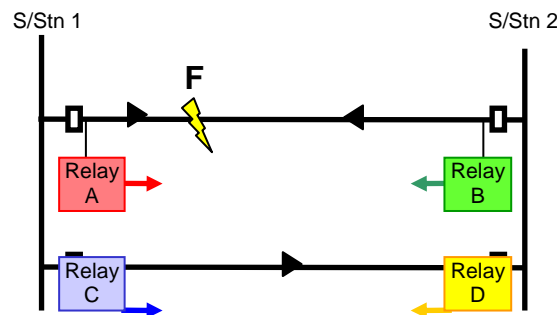

Both Relay A and Relay B will detect earth fault current in the forward direction. Both DEF elements will operate, permissive signals will be sent by both relays, and when these signals are received, Relays A and B will carry out a *DEF Aided Trip*, isolating the fault.

Observing the direction of current flow, Relay C will also detect earth fault current in the forward direction, and send a permissive signal to the remote end (Relay D). Relay D will detect earth fault current in the reverse direction, and will not operate when the permissive signal is received from Relay C.

Now consider a situation, where the circuit breaker controlled by Relay B operates slightly before the circuit breaker at A.

The direction of current seen by relays C and D will change, so Relay C will detect earth fault current in the reverse direction, and relay D will detect earth fault current in the forward direction.

Under these circumstances, there is a "race condition" between the drop off of the *Signal Send 2* output from relay C and the operation of the forward DEF element at relay D.

If the DEF element at D operates before the *Signal Send 2* from Relay C drops off, Relay D may mal-trip.

Thus, if the Circuit Breaker is closed, the relay does not detect fault current in the forward direction, a residual voltage is present on the system, and a permissive signal has been received from the remote end, the *Current Reversal Guard* logic is started. If the relay then detects a forward DEF it will enforce a time delay (the *DEF Current Reversal Reset*) on the DEF Aided Trip to allow the remote end *Signal Send 2* element to drop off, and ensure stability of the protection.

2.1.2.2 CB Echo

The DEF POR scheme relies upon relays at both ends of the line detecting the fault. With the circuit breaker at one end of the line open, the DEF element at one end cannot operate. Thus no permissive signal can be sent, so the fault would be cleared after a time delay as a back-up trip for an in-zone fault.

Thus, if the local Circuit Breaker is open AND a permissive signal is received from the remote end, the relay will send (or "echo") a permissive signal back to the remote end. The duration of this permissive signal is set as the *POR CB Echo Pulse Width*.

3 Relay Settings

3.1 DEF Auxiliary Protection Settings.

DEF Protection - Allows the DEF Element to be enabled or disabled

DEF Active Scheme - Active scheme may be set as either DEF POR or DEF Direct trip. For more details on these schemes see part 2.1 of this section.

DEF Char Angle - Defines the maximum torque angle of the DEF element. The relay will operate in the region within $\pm 85^\circ$ of this angle.

DEF Direction - May be set forward or reverse. Normally set to look in the forward direction.

DEF IDMTL Setting - Defines the current pickup setting of the DEF element.

DEF IDMTL Char - Defines the characteristic used for the IDMTL element.

The choices are as follows:

IEC-NI, VI, EI, LTI,

ANSI-MI, VI, EI

Definite Time Lag (DTL)

DEF IDMTL Time Mult (IEC/ANSI) - Defines a time multiplication factor to be applied to the standard curve.

DEF IDMTL Delay (DTL) - Sets the DTL delay if the IDMTL characteristic is selected as DTL.

DEF IDMTL Reset - Allows the reset time of the element to be defined as Instantaneous (INST), Decaying, or a definite time (0-60s)

DEF CRG Res OV Setting - This sets the level of residual overvoltage which must be present for the Current Reversal Guard Logic to be activated.

DEF Current Rev Reset - Time delay for which the relay will restrain following a reversal in current direction. (See part 2.1 of this section)

CB Echo Pulse Width - If the local CB is open, and a signal is received from the remote end this is the length of time for which the Signal Send 2 output will be energised for. (See part 2.1 of this section)

3.2 DEF Protection Status Inputs

Block DEF – Energising this Status Input will inhibit the operation of the DEF element.

Signal Received 2 – This is energised by the operation of the remote end instantaneous.

Carrier Guard – This is designed to be energised by the failure of the signalling channel (i.e. from a channel not healthy contact on the signalling equipment). When energised it will prevent a DEF aided trip. The relay will be able to carry out a time delayed back-up trip.

3.3 DEF Protection Outputs

The *DEF Protection* output operates for any DEF Operation (aided or back-up), and the *DEF Aided Trip* output will only operate for an aided DEF trip.

Signal Send 2 – This will pick-up when the relay is in DEF POR mode and an Overcurrent starter has operated.